

FLOOR DOOR

Side B	Side C	Side D	VERSION	H LIGHT	H FRAME	FRAME	WINDOW	GLASS	ACCESSORIES
		1	Standard Galvanized RAL 7024*	78 3/4"	84 1/4"	Galvanized and RAL 7024	Panoramic	Fumè	Ditec - C2 - PM
2			Standard Galvanized RAL 7024*	78 3/4"	84 1/4"	Galvanized and RAL 7024	Panoramic	Transparent	Ditec - C2 - PM
3			Standard Galvanized RAL 7024*	78 3/4"	84 1/4"	Galvanized and RAL 7024	Absent		Ditec - C2 - PM

C1 = Enabling key for the floor button pad (single insertion) C2 = Enabling key for the floor button pad (double insertion) PM = Button pad on the wall PE = Outside lock and button pad

* All floor doors with smooth edges

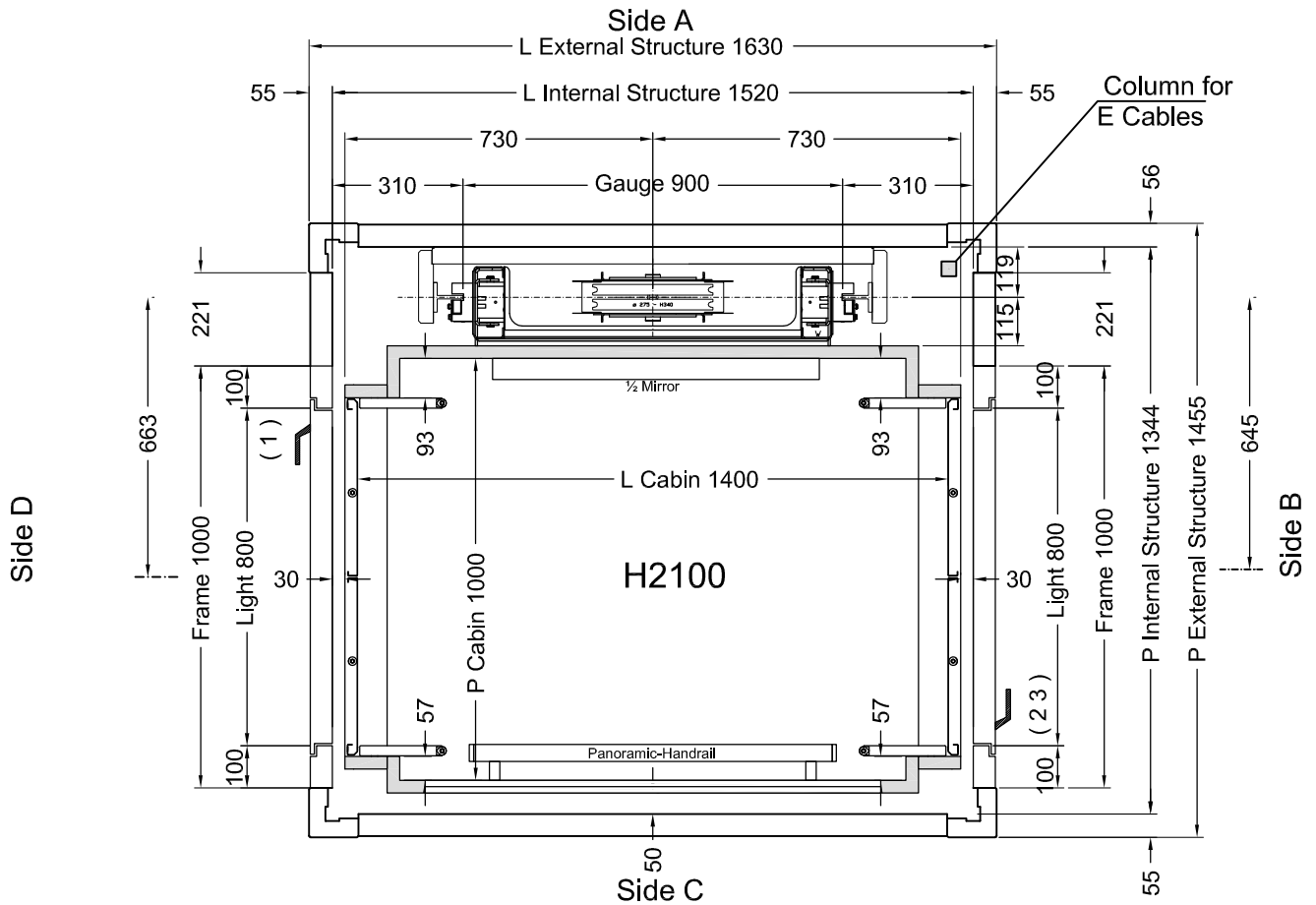

Feasibility n° 2236

Stops: 3 - Doors: 3

Shaft in **Shaft V52 ()**

		Designer	Date	II Rev. Final Design	
		D.Ogliastro	05/06/2015	Model	SHEET
		D.Ogliastro	29/05/2015	ELFO	1/4
		D.Ogliastro	20/05/2015		SHEET DIMENS.
		D.Ogliastro	22/12/2014		A3
	Final Design D.Ogliastro	1° STESURA 29/05/15		SCALE	1:12.5
	CAPACITY	AREA R ²	CAPACITY		
	990 lbs	14,66			

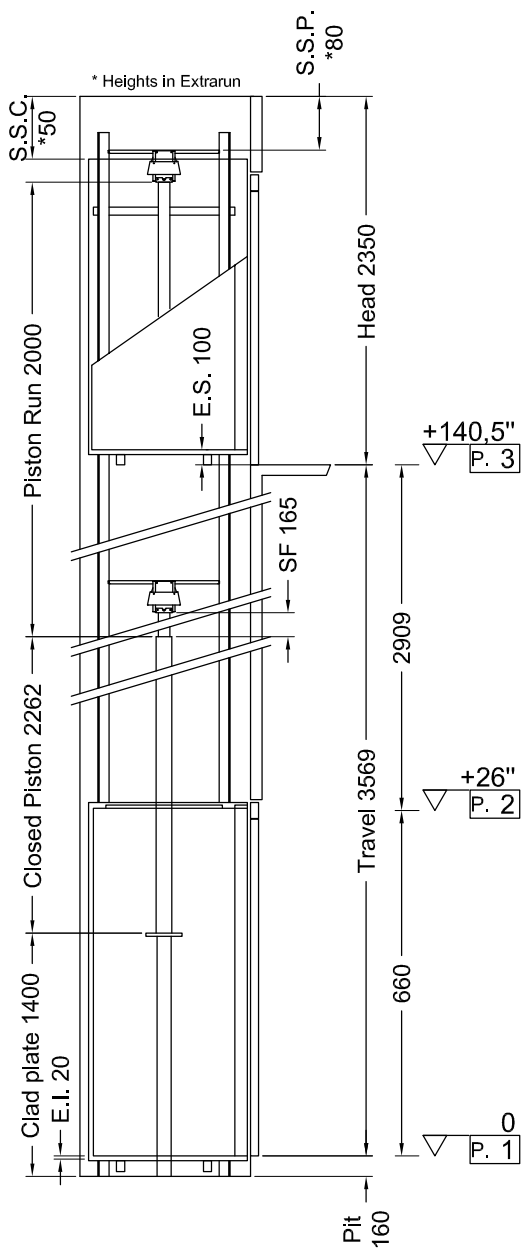

Indirect Installation Speed 40 fpm 16/04/14 10.42 (V.2844)

THRUST DURING NORMAL OPERATION			THRUST OF SAFETY DEVICE INTERVENT		
P	(lbf)	3187	P	(lbf)	129
N	(lbf)	130	N	(lbf)	2125
F1	(lbf)	411	F1	(lbf)	685
F2	(lbf)	105	F2	(lbf)	175

SPACES		PRESSURES	
E.I.	Extrarun below cabin	13/16"	Max static pressure (bar) 36,64
E.S.	Extrarun above cabin	3 15/16"	Min static pressure (bar) 17,12
SF.	Piston extraction	6 3/8"	Overpressure limit (bar) 51,29
S.S.P.	Piston/head	6 3/8"	Residual pressure (bar) 1,14
S.S.C.	Cabin/head	13/16"	

HYDRAULIC UNIT		MECHANICAL PARTS	
Central unit	GMV HL 3010 (-*)	Guide rails	70x70x9
Capacity (l/min)	30	Brackets	(Nr) 7
Motor (V)	MF230V 60 Hz	Ropes	Ø 11 mm 6-(1+9+9)
Power (Kw)	2,9	Cables length (mm) 2 x	9000
Nominal current (A)	-	Min actual breaking load (N)	70700
Piston	START SL (ø)80x5x2000		
Opt. oil position	BASSO		
Tubing	3/4" EN 853 1SN - FD 3/4" - FD 3/4"		
Tubing length (mm)	13000		
Min hydraulic oil (L)	46		

SECURITY DEVICES	Manufacturer	Model	Certificate
Safety Gear	PFB	BP1	TÜV AFV515
Block Valve	START ELEVATOR	1/2" 0326	CA50.00526
Key Locks	Prudhomme	PLT/L/CPX NL 11-400-1002-125-02	

MACHINERY LOCATION			
At floor	1	Length of the hose travel	28 (Ft)
Cables enter in shaft: Side	C	Hydraulic unit model	-*

CABIN		CABIN ACCESSORIES	
Panels	Inox Scotch Brite	½ Mirror	Lati A
Finishes	Inox Scotch Brite	Panoramic	Lati C
Oper. panel	HORIZONTAL	Outside covering	Side B,C,D
Floor	ROCK SOLID 677	Outside finishing	Inox Scotch Brite
Ceiling	SPOTS LED - Inox Scotch Brite	Handrail	INOX S.B., Lati C
Cabin Doors	Side B: AUTOMATIC folding door, Inox Scotch Brite Ext.cov.panoramic transparent Side D: AUTOMATIC folding door, Inox Scotch Brite Ext.cov.panoramic transparent		

- OTHER ACCESSORIES**
- Enabling key for the cabin button pad, double insertion
 - Mechanic painted RAL 9005 + Piston painted RAL 9005
 - 50x50 buttons
 - Pan for oil recovering
 - Manual pump
 - Manostat with overweight signal
 - Two speed
 - Return to the lower floor after adjustable time
 - Ditec
 - False head device
 - Handles CASPIM
 - Cabinet: Inox Scotch Brite
 - Guides dimension 98 7/16"
 - Open doors button In cabin
 - Prepared for autodialer





ORDER
C

Final Design

1° STESURA



C Class Fumidà

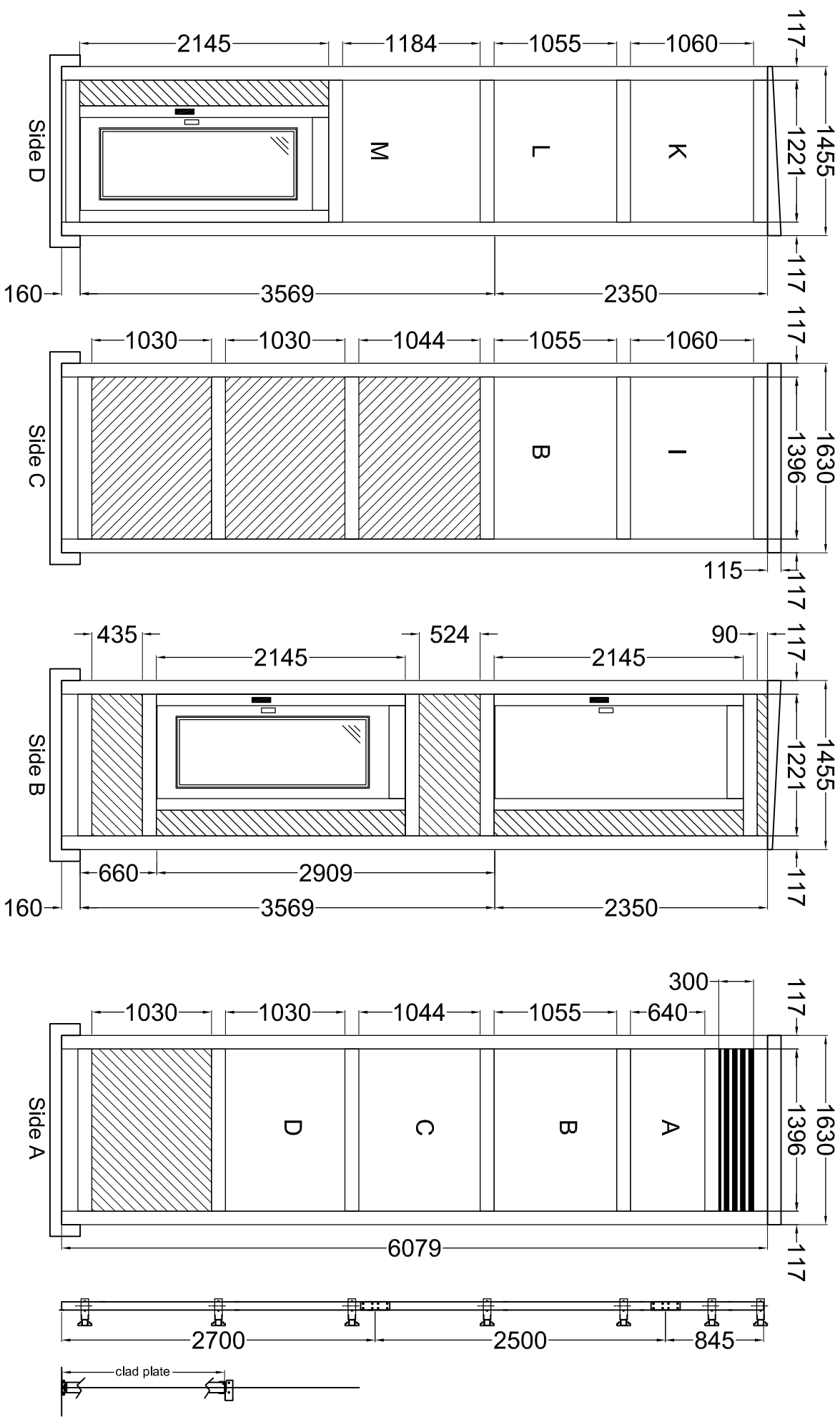

Anchorage in height of 3 frames in head and every 3.5 m max

ENVIRONMENT	VERSION	CLADDING	START	ROOF	ANCHORAGE
Outside	**	See page 3	Pit bottom	For Outside	Anchorage to care of the Customer Sides A and B. Ancoraggio a cura del Committente Latit A e B.
Esterno	**	Vedi Pag. 3	Fondo Fossa	Per esterno	

Shaft V52 0