

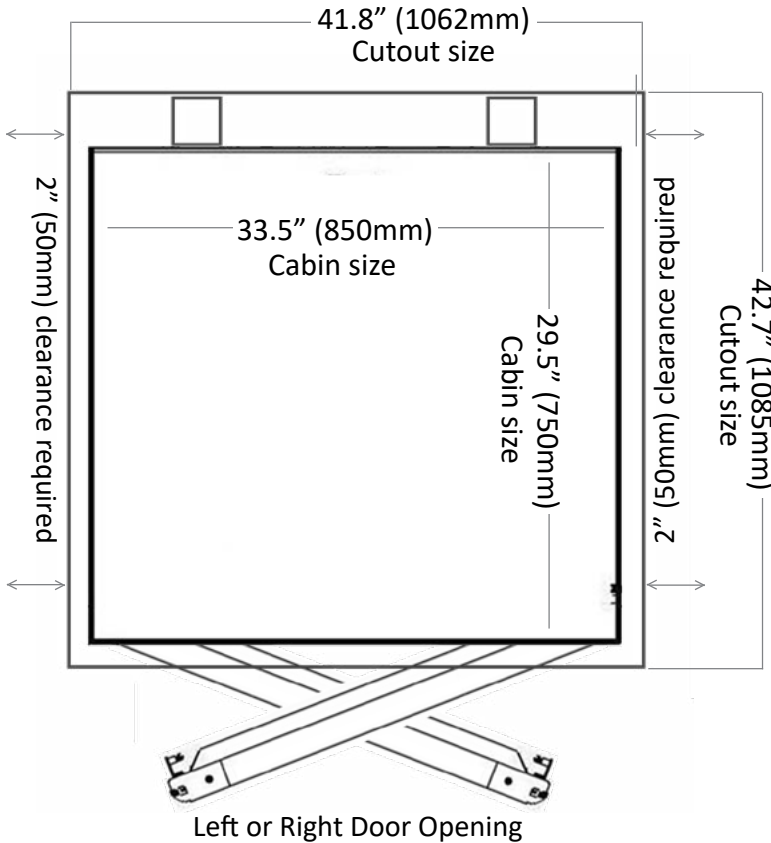

The award winning leader

Q1 • Medium • Pre-Engineered

Plan View



Top Floor Section View

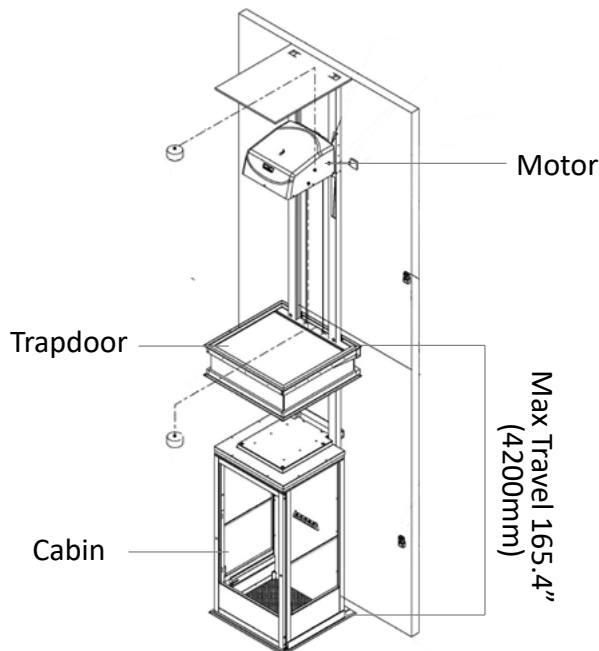
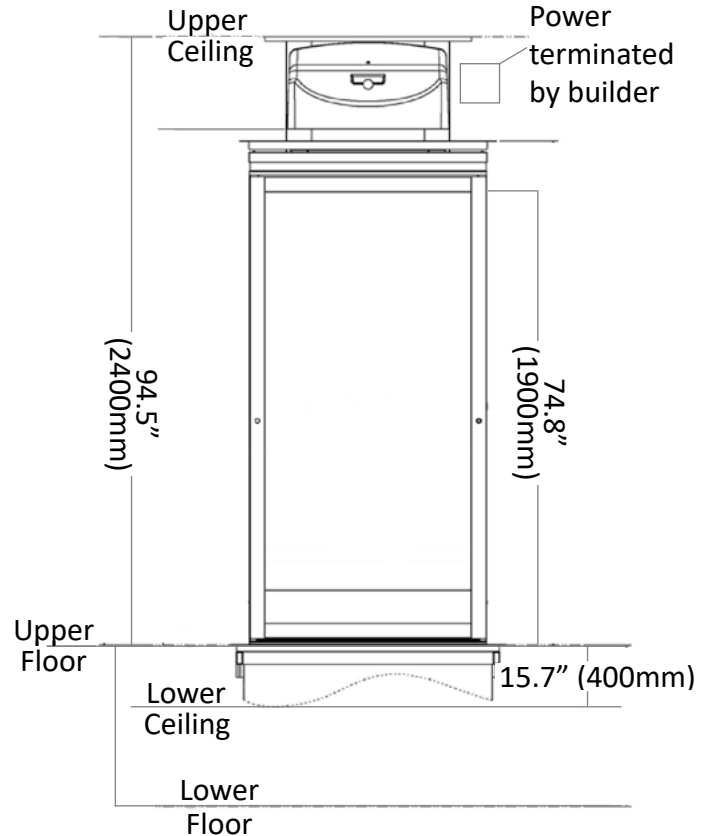

Construction Details

- Pit depth No pit required
- Headroom 94.5" (2400mm)
- Power supply Single phase 230 V 50/60 Hz, 20A
Location to be agreed

Standard Specifications

- Person capacity 3 persons / 562.2lbs (255kg)
- Cabin height 74.8" (1900mm)
- Door width 33.5" (850mm)
- Speed 15.7fpm (0.08m/s)
- Maximum travel 165.4" (4200mm)
- Maximum floors 2
- Compliance EN81-41
- Safety Sensors top and bottom of cabin
- Pre-engineered held in stock