

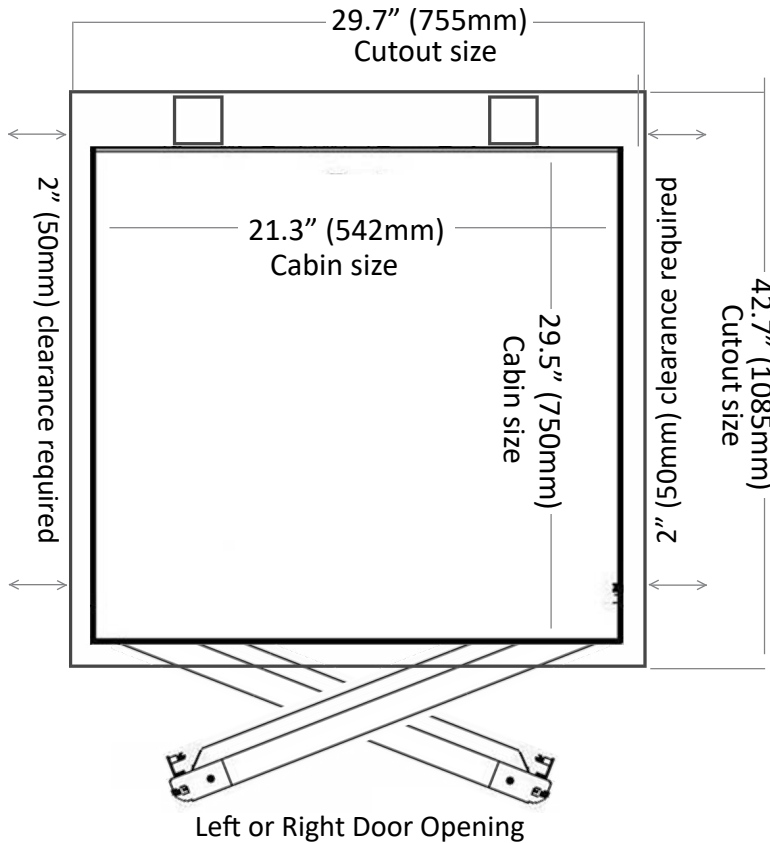

The award winning leader

# Q1 • Small • Custom

## Plan View



## Top Floor Section View

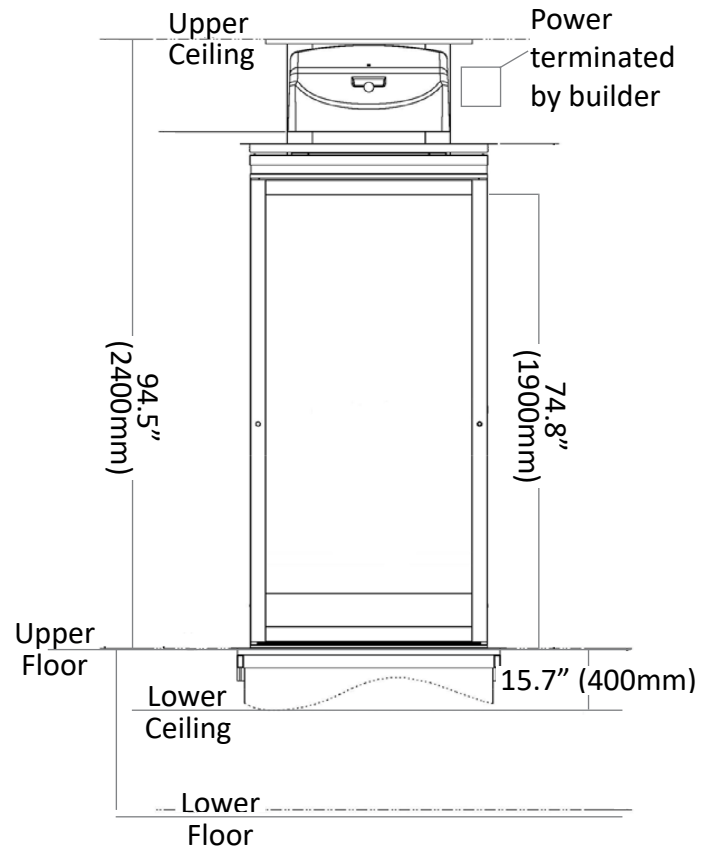

## Sketch

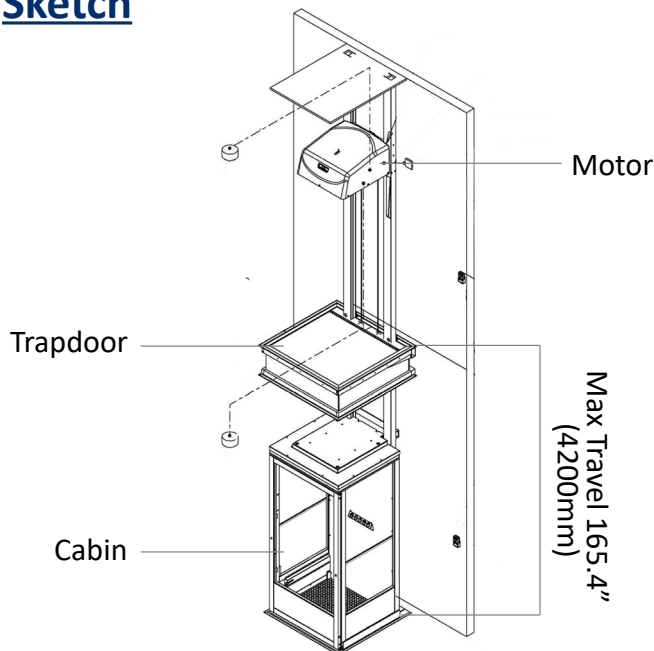

## Construction Details

- Pit depth No pit required
- Headroom 94.5" (2400mm) - allow 3.9" (100mm) extra for high speed
- Power supply Single phase 230 V 50/60 Hz, 20A Location to be agreed

## Specifications

- Person capacity 3 persons / 562.2lbs (255kg)
- Cabin height 74.8" (1900mm)
- Door width 21.3" (542mm)
- Speed 15.7 - 29.5fpm (0.08 - 0.15m/s)
- Maximum travel 165.4" (4200mm)
- Maximum floors 2
- Compliance EN81-41
- Safety Sensors top and bottom of cabin
- Large selection of colours available