

**ELEVATOR
BOUTIQUE**



life with style



Q1

Made in the UK

8 Reasons why to choose Elevator Boutique

01 CERTAINTY

A showroom visit lets you experience the elevator before you own it.

Showroom visits are essential to help you learn and experience the proposed elevator system.

Informed and educated purchasers usually select the best. So research your many options carefully.

02 THE SAFEST ELEVATORS

Rescue feature is a standard inclusion.

24/7 call centre assistance.

Fully code compliant.

Full height infra-red light ray curtains.

Auto lower and unlocks in the event of a power failure.

03 THE LEADER FOR TECHNOLOGY

2 speed drives for maximum speed with smooth acceleration.

Computer monitoring of the latest elevator functions for efficient diagnosis and repair.

Sized to suit, and styled to suit, has always been the Elevator Boutique advantage and the big difference from others.

04 SUPPORT & FREE INCLUSIONS

After your order is placed we have full time and dedicated, Construction Support, Site Managers, and Installation Teams to ensure your elevator is built on time and budget.

The Elevator Boutique team is coordinated by our custom database which tracks everything.

We are the experienced and proven solution for a stress-free delivery of your elevator.

05 UNBEATABLE VALUE

Our formula is:

Elevators – proven long history, stable and secure manufacturer, ultra-reliable premium quality.

Volumes – Elevator Boutique sells more elevators than any other American home elevator specialist.

Costs – Annual costs shared by 5 offices, 700+ new elevators clients, and thousands of routine service clients.

We do not have hidden extras.

06 A GENUINELY GREAT REPUTATION

Check Google Reviews.

100's of genuine, original testimonials from real clients can be read in our showrooms.

Independent awards and recognition.

07 LOW SERVICE COSTS

Elevator Boutique only services and maintains its own quality elevators with full technical support/ spares in America.

Other companies elevators distract from the attention good clients deserve.

We focus on you.

08 THE NO.1 HOME ELEVATOR SPECIALIST

We are America's largest residential elevator company.

The undisputed leader in Italian elevators.



UK made - Q1

Why It's Awesome

- Quick supply and installation
- Faster than the competition
- Great value and a low price
- Minimal building works required (just a hole in the floor)
- Small footprint and self contained system means no shaft space
- Low power consumption
- A compact and elegant solution
- Made in the United Kingdom
- The safest compact elevator on the market





Q1 - Pre-Engineered

Lift Sizes	Medium 33.5" x 29.5"	Large 33.5" x 49.2"
Cutout size	41.8" x 42.7"	41.8" x 62.4"
Opening	Single	
Max travel	13.8' - 2 floors	
Persons load	562.2lbs - 3 persons	
Finish	RAL Powdercoat 7035	
Lighting	LED	
Control buttons	2 remote's	
Vision panels	Perspex	
Rails	Aluminum	
Flooring	Vinyl - Mottled Battle Ship	
Phone	Black Handset	
Control panel	Black vertical	
Rear cladding	RAL Powdercoat 7042	
Cabin height	74.8"	
Pit	No pit required	
Headroom	94.5" (for slow speed - 15.7fpm) 98.4" (for fast speed - 29.5fpm)	
Compliance	Refer to your local AHJ	



Q1 - Custom Options

- **Faster speed – 29.5fpm (+ 4" for headroom)**

- Small 1 person size available (21.3" x 29.5" cabin / 29.7" x 42.7" cutout)

- Special custom RAL colors

- Mirror in fill panels

- Handrail

- Tip-up seat

- Power operated door

- Auto dialer

- LED display panel

- Mood lighting

- Blue tooth activation

- Upgraded flooring

layout drawings

Plan View

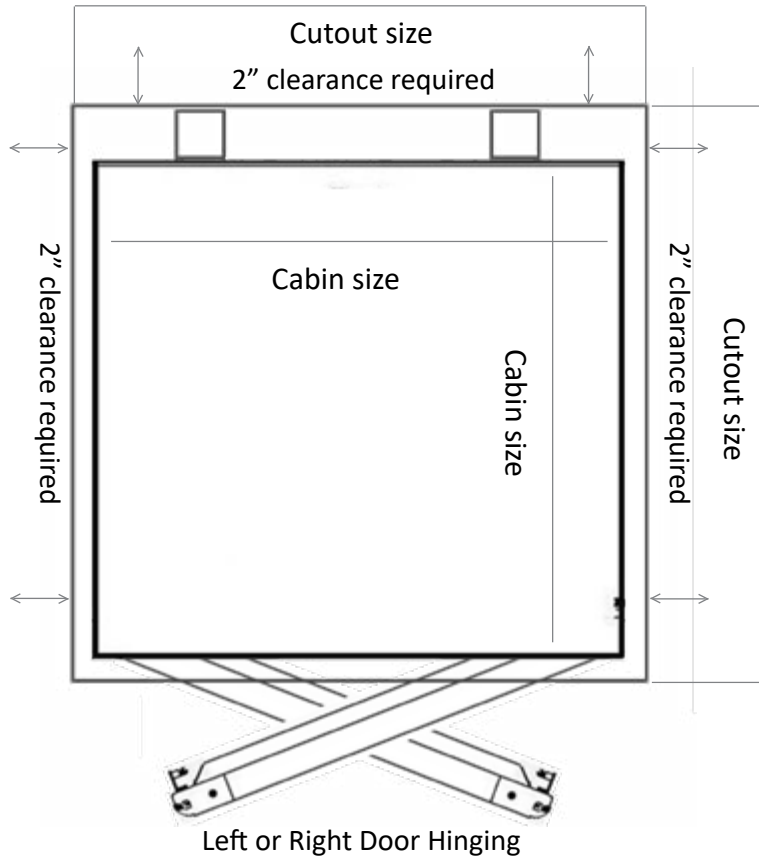

Top Floor Section View

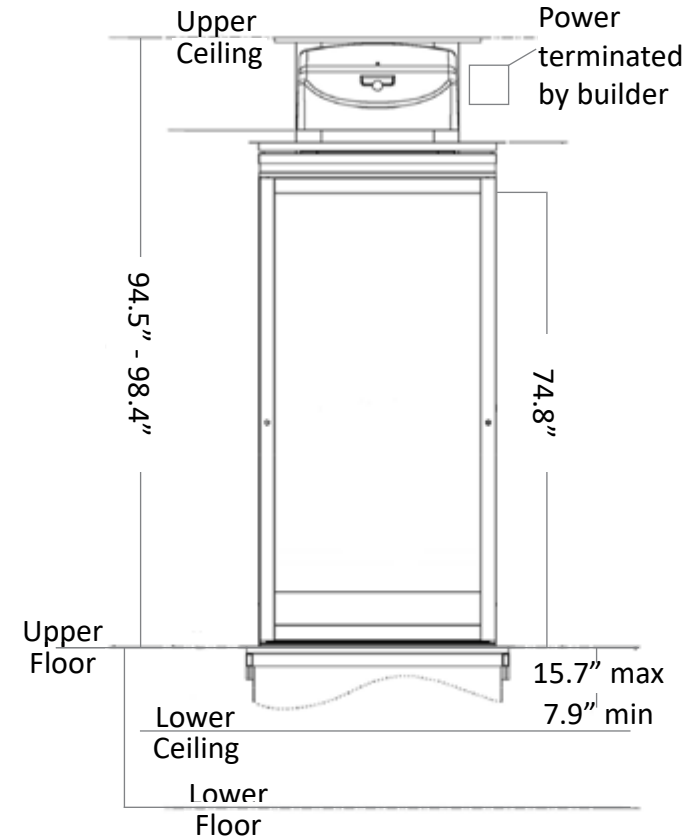

	Small	Medium	Large
Cabin width	21.3"	33.5"	33.5"
Cabin depth	29.5"	29.5"	49.2"
Cutout width	29.7"	41.8"	41.8"
Cutout depth	42.7"	42.7"	62.4"



sketch

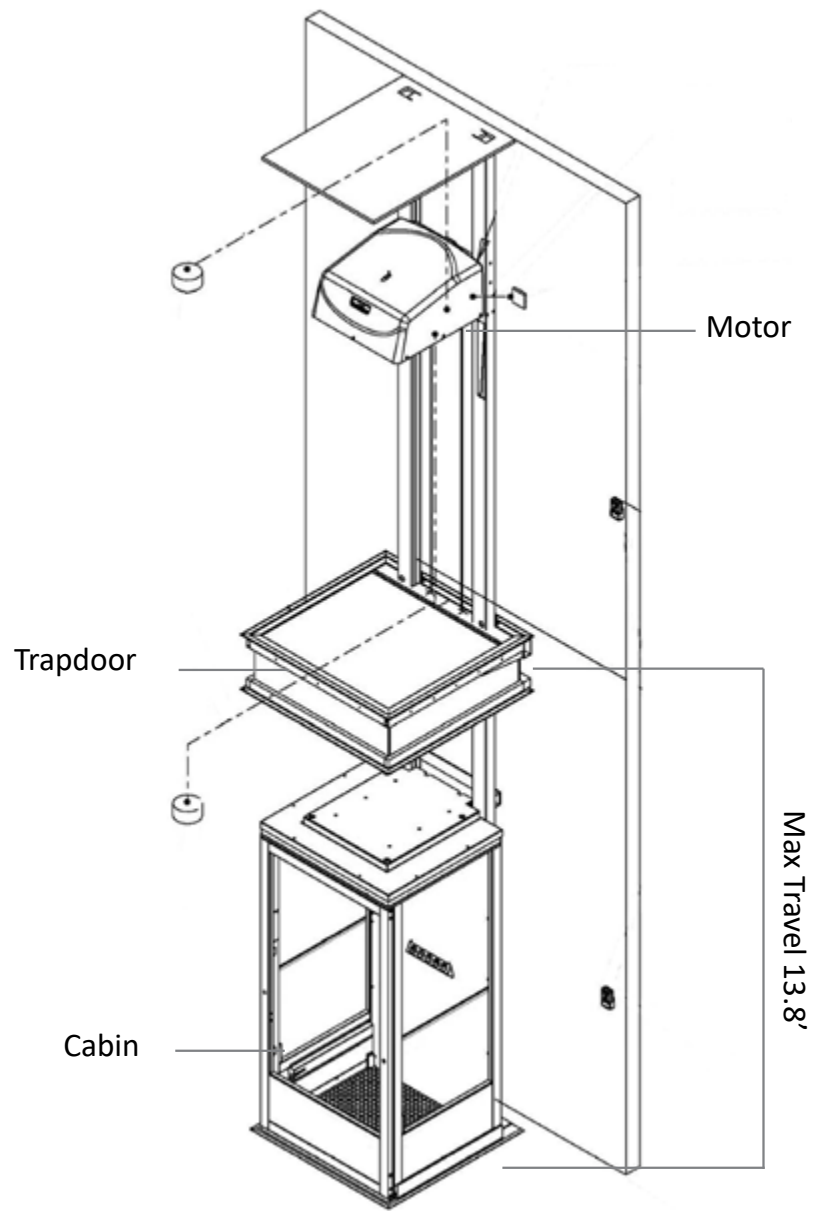

finishes

Lift Colours



Clear Perspex



RAL
Powdercoated

Flooring

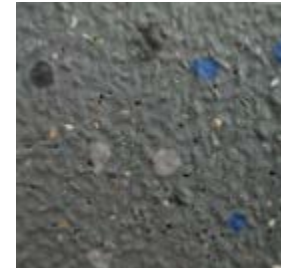

Vinyl - Battleship

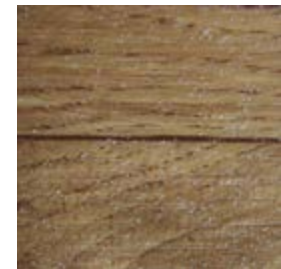

Vinyl - Light Oak



Vinyl - Marble Mist



LOS ANGELES

Pacific Design Center
Blue Building - Suite B-110
8687 Melrose Avenue
West Hollywood CA 90069
T 855 326 8847



SYDNEY

1/75 Corish Circle
Eastgardens NSW 2036
T 02 9666 3939



MELBOURNE

1/1 Belgium Avenue
Richmond VIC 3121
T 03 9421 4222



BRISBANE

4/300 Cullen Avenue East
Eagle Farm QLD 4009
T 07 3014 0633



PERTH

5/75 Robinson Avenue
Belmont WA 6104
T 08 9460 0666

elevatorboutique.com
855 326 8847

Awesome